



# TAI-SAW TECHNOLOGY CO., LTD.

No. 3, Industrial 2nd Rd., Ping-Chen Industrial District,  
Taoyuan, 324, Taiwan, R.O.C.

TEL: 886-3-4690038 FAX: 886-3-4697532

E-mail: [tstsales@mail.taisaw.com](mailto:tstsales@mail.taisaw.com) Web: [www.taisaw.com](http://www.taisaw.com)

## Approval Sheet For Product Specification

Issued Date:

Product Name: SAW Resonator 915 MHz SMD 5X5 mm

TST Parts No.: TD0106A

Customer Parts No.: \_\_\_\_\_

Company: _____
Division: _____
Approved by : _____
Date: _____

Checked by: Vincent Liu

Approval by: Francis Chen

Date: 2002/10/10



# TAI-SAW TECHNOLOGY CO., LTD.

No. 3, Industrial 2nd Rd., Ping-Chen Industrial District,  
Taoyuan, 324, Taiwan, R.O.C.

TEL: 886-3-4690038 FAX: 886-3-4697532

E-mail: [tstsales@mail.taisaw.com](mailto:tstsales@mail.taisaw.com) Web: [www.taisaw.com](http://www.taisaw.com)

## SAW Resonator 915 MHz

MODEL NO.: TD0106A

REV. NO.:1

### A. FEATURES:

1. 2-Port Resonator.

### B. MAXIMUM RATING:

1. Input Power Level: 0 dBm

2. DC voltage: 12 V

3. Operating Temperature: -40°C to +85°C

4. Storage Temperature: -40°C to +85°C

### C. ELECTRICAL CHARACTERISTICS:

Characteristic	Units	Minimum	Typical	Maximum
Center frequency <b>Fr</b>	<b>MHz</b>	914.850	915.000	915.150
Insertion Loss <b>IL</b>	<b>dB</b>	-	8	9
Equivalent Elements				
Motional capacitance <b>C1</b>	<b>fF</b>	-	0.225	-
Motional inductance <b>L1</b>	<b>μH</b>	-	134.5	-
Motional resistance <b>R1</b>	<b>Ohm</b>	-	125	-
Parallel capacitance <b>Co</b>	<b>pF</b>	-	1.9	-
Temp.coeff.	<b>ppm/c*2</b>	-	0.032	-
Turnover To	<b>deg.C</b>	-	25	-
Package size		SMD 5X5X1.4mm		

RoHS Compliant  
Lead free  
Lead-free soldering

### D. OUTLINE DRAWING:

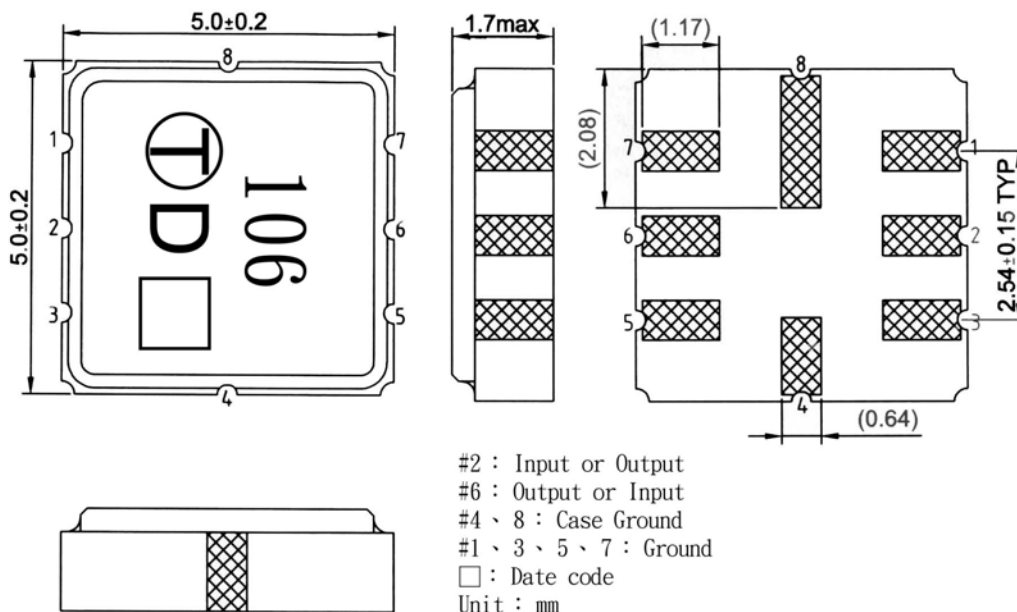

E. EQUIVALENT CIRCUIT:

Two-Port Resonator:

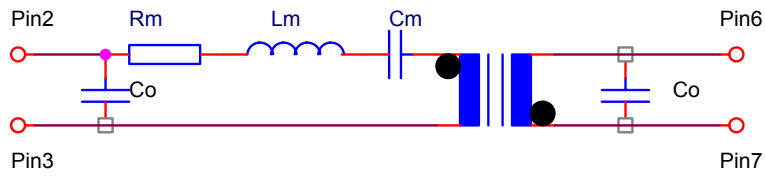

F. FREQUENCY CHARACTERISTICS:

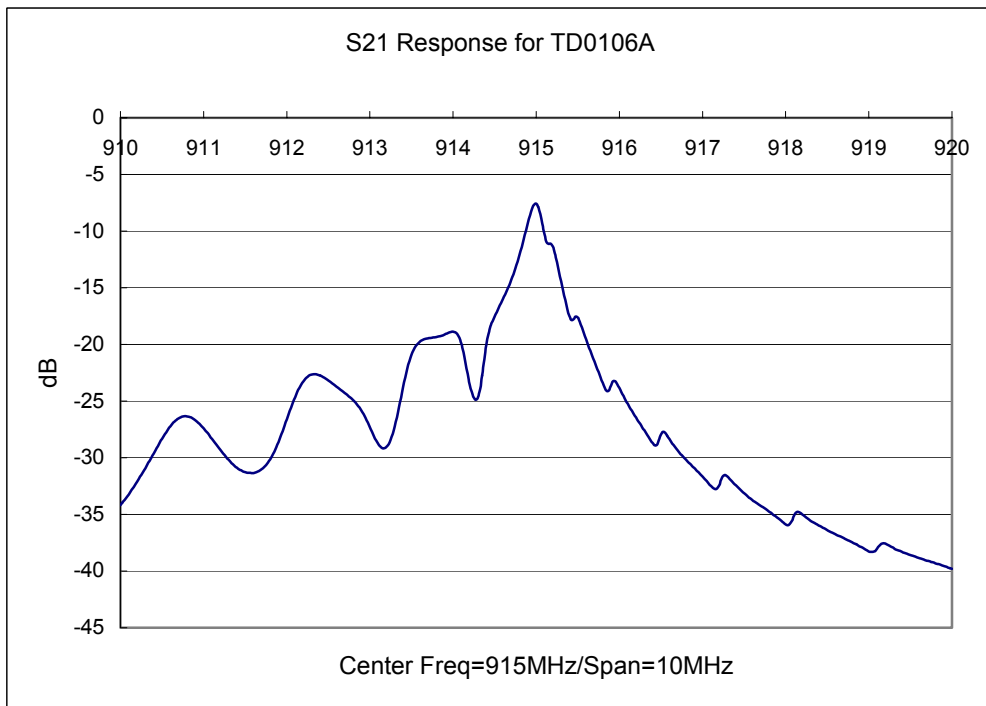

G. TEST CIRCUIT:

Network analyzer

From 50Ω  
Network  
Analyzer

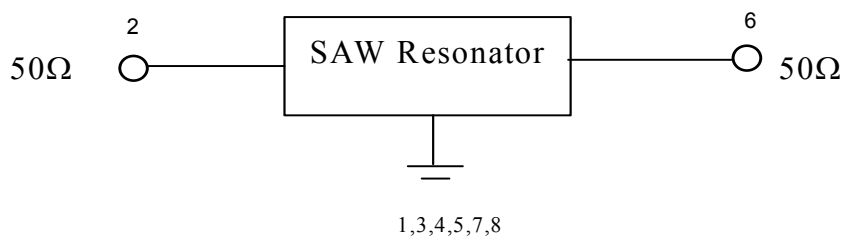

To 50Ω  
Network  
Analyzer

## H. PACKING:

### 1. REEL DIMENSION

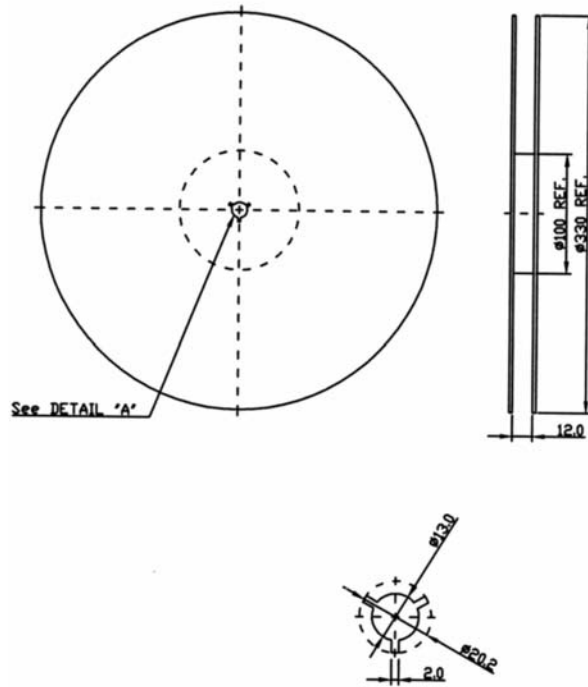

### 2. TAPE DIMENSION

